

Product data sheet

Characteristics

9070TF100D2

Transformer, Type TF, industrial control, 100 VA, 240/480 VAC primary / 24 VDC secondary, 1 phase, 50/60 Hz, 55 °C rise



Product availability: Stock - Normally stocked in distribution facility

Price*: 230.00 USD



Main

Product or component type	Industrial Control Transformer
Rated power in VA	100 VA
Primary voltage	240 x 480 V
Secondary voltage	24 V
Range of product	TF

Complementary

Phase	1 phase
Rated power in VA	100 VA
Primary voltage	240 x 480 V 24 V
Fuse type	10.3 x 38 mm CC top
Temperature rise	55 °C
Electrical connection	Screw clamp terminals
Product compatibility	FSC1

Environment

Product certifications	CSA UL Listed
NEMA degree of protection	Not rated (open device)
Insulation temperature	221 °F (105 °C)

Ordering and shipping details

Category	16202 - 9070 TF (NOT T) 50-200VA
Discount Schedule	CP8
GTIN	00785901905219
Nbr. of units in pkg.	1
Package weight(Lbs)	4.46 Lb(US) (2.023 kg)

Returnability	Yes
Country of origin	MX

Packing Units

Unit Type of Package 1	PCE
Package 1 Height	4.27 In (10.846 cm)
Package 1 width	3.35 In (8.509 cm)
Package 1 Length	3.38 In (8.585 cm)

Offer Sustainability

Sustainable offer status	Green Premium product
California proposition 65	WARNING: This product can expose you to chemicals including: Phenyl glycidyl ether, which is known to the State of California to cause cancer and birth defects or other reproductive harm. For more information go to www.P65Warnings.ca.gov
REACH Regulation	REACH Declaration
EU RoHS Directive	Compliant EU RoHS Declaration
Mercury free	Yes
RoHS exemption information	Yes
China RoHS Regulation	China RoHS Declaration
Environmental Disclosure	Product Environmental Profile
PVC free	Yes

Contractual warranty

Warranty	18 months
----------	-----------

Approximate Dimensions

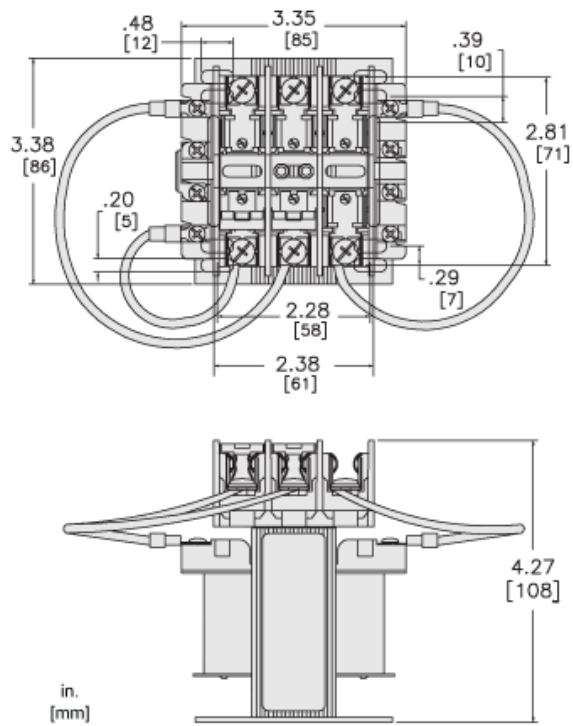

Product Life Status : **Commercialised**